

Type E Cavitytray

for insertion into existing walls

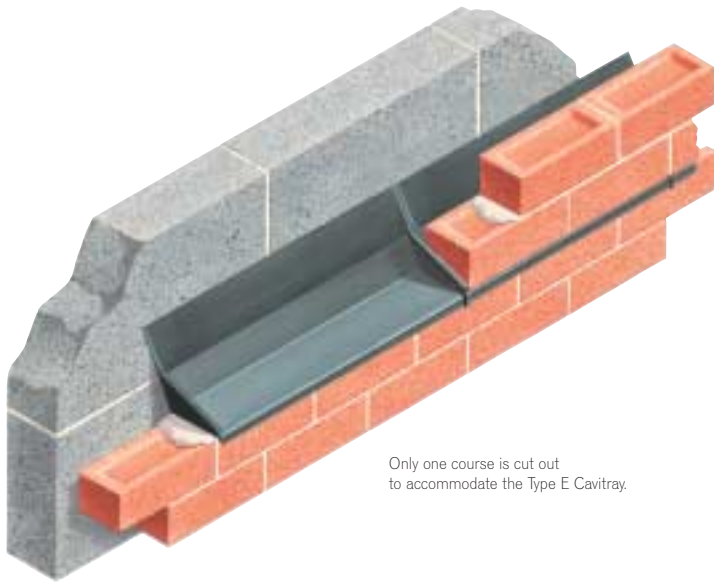

Only one course is cut out to accommodate the Type E Cavitytray.

- Brick-sized cavitytrays permit progressive insertion
- Anticapil interlocking to form long runs
- Cavity widths compatible - upstand adjusts to suit
- Unobstructed cavity compartment area with stand-alone discharge
- Easy compliance with building regulations
- Minimal disturbance to masonry - fitted from outside

problem

To damp-proof an original outside wall which has become an inside wall by virtue of an extension being built. Also suitable for remedial work where an existing DPC has failed. See next product entry describing Type E for remedial and corrective applications.

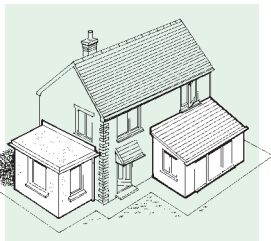

introduction

When an extension is added to a building, the problems of inserting a DPC at the horizontal intersections must be faced. By present methods this is not an easy operation. In many cases complete strutting is necessary. In all cases the amount of brickwork which must be cut away to permit the insertion of a DPC extends to 300mm or more in depth. This means four courses of bricks for the whole length of the DPC. In the case of the shored wall, there is considerable making good to brickwork, plasterwork, ceiling and decoration. The use of the

Type E cavitytray overcomes all these problems.

solution

The Type E is a preformed DPC unit, two bricks in length. There are upstands at either end of each tray that clip together. Trays are inserted into a cavity wall one at a time. Long runs are thus created with a series of connected but self-contained Type E units. The preformed ends coincide with masonry perp joints. No reliance is therefore placed on gluing or sticking adjoining lengths - an exercise that can be difficult when inserting any DPC medium.

All Type E cavitytrays have an extended cavity upstand that runs the length of the tray. The upstands automatically adjust for any cavity width from 50mm up to 120mm, ensuring compatibility with the cavity encountered. The front projecting lip of each tray is designed to provide protection of the bedding course against wind-driven rain. Apart from the financial saving, the advantages of the preformed Type E cavitytray are considerable. There is no shoring and therefore no making good, thus workmen

do not need to enter the building. Only one course of brickwork is disturbed therefore no large scar remains after insertion. Time taken to install represents a small fraction of time taken by the traditional method. The awkward and sometimes suspect running joints of a normal DPC or tray installation are eliminated. The adjustable cavity upstand accommodates the 'as built' cavity status rather than the anticipated status. Type E cavitytrays are extensively used on commercial, industrial,

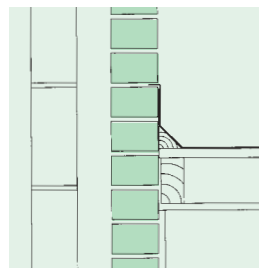

Rain penetrates the external skin, which becomes an internal skin below the new roofline.

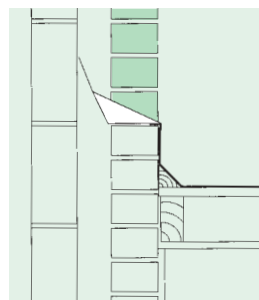

Type E cavitytrays with extended flexible upstands are particularly suitable for non-standard or varying cavities.

educational and domestic extension work.

sizes

The standard cavitytray sizes shown suit most brick dimensions. The unique U clip design enables adjoining trays to be slightly 'adjustable' to help match existing bond. Please compare your brick size with our standard tray size. Notify us should you require alternative dimensions, such as to accommodate old imperial bricks. Trays can be supplied in almost any special size.

material

Polypropylene solid DPC, injection moulded to ensure uniform thickness. Trays can also be supplied in other materials to suit special applications.

colour

Black.

installation/site work

Cut out masonry in the external skin of cavity wall in accordance with the installation instructions provided by Cavity Trays of Yeovil. Insert one at a time into the existing external skin. Incorporate flashing under cavitytray if appropriate.

designers' comments

The positive upstand jointing between trays was established many years ago as our most reliable format. We rejected overlapping and sticking as, in our tests it proved less reliable as the integrity of the adhesion/join in the cavity spanning portion was unsupported and, being an existing wall, the access/working space to make the overlap was limited. The superior results we obtained when anticapil clipped together dictated we adopt the cavitytray with end upstands. It is interesting to note that each tray being self-contained, means pinpointing of any area problem can be located/identified with accuracy and speed - not an easy task with the alternative stick together/open run format. The rigid panoplied lip has proved essential in exposed applications and high intersections. Stopends and weeps are promoted in BS8215:1991 and the latest BS 5628:3-2001. These features have formed part of our Type E system for many years, thus Type E cavitytrays more than satisfy the latest standards. Type E cavitytrays also have a cavity upstand height of 150mm to satisfy the standard requirements - a dimension which is not matched by all manufacturers.



Type E Cavity Tray

for insertion into existing walls

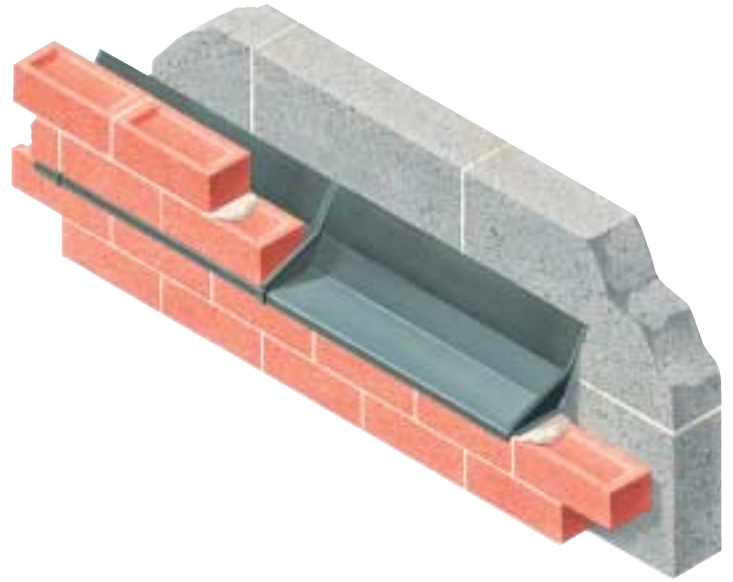

- Brick-sized cavitray permits progressive insertion
- Anticapil interlocking to form long runs
- Cavity widths compatible - upstand adjusts to suit
- Unobstructed cavity compartment area with stand-alone discharge
- Easy compliance with building regulations
- Minimal disturbance to masonry - fitted from outside

DAMP-PROOFING

technical observations

Positive jointing integral anticapil clip eliminates gluing, sticking or overlapping. Shape and depth of projecting lip prevents discharge water permeating the bedding joint - an often overlooked consideration on exposed sites. Adjustable cavity upstand accommodates cavity size variations. Unobstructed tray cavity compartment. Features classify Type E cavitray as high performance. Branded with name and logo as proof of type and accompanying warranty.

Replace bricks into the cavitray within the wall. Ensure tray and all bricks are correctly bedded in mortar. Slate pin to make safe and firm. Incorporate weepvent in the middle of each cavitray. Adjoining trays clip together automatically. Continue operation until required run is completed. Ensure all installation is strictly in accordance with manufacturer's instructions.

bill of quantity wording

Type E cavitray from Cavity Trays of Yeovil, Somerset BA22 8HU (01935 474769). Size as standard (or specify size of tray required). Total run in metres = Request liability/conformity document upon completion.

ordering/regulations

See inside back cover for details.

related products and applications

See entry under Type E Remedial for solving dampness problems within existing structures.

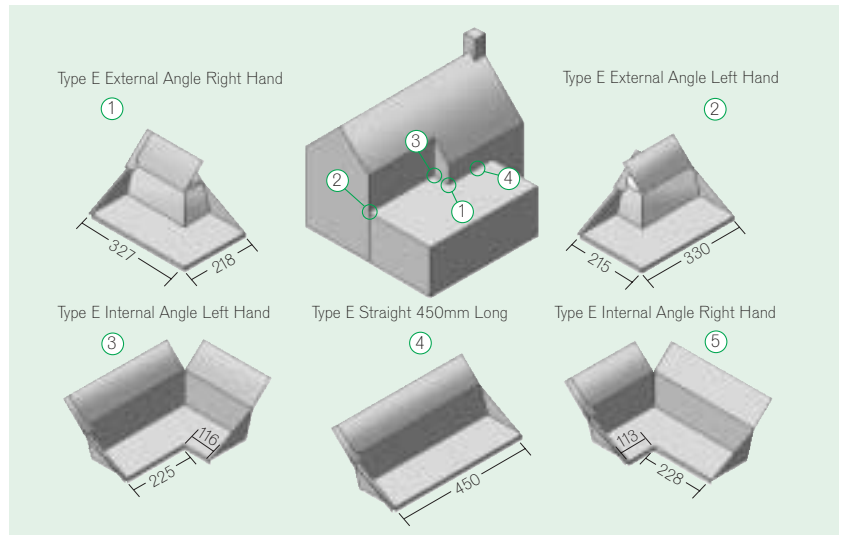

For new-build horizontal applications see Type G entry. Type E Cavitrays discharge arrested water via perp weepvents - see entries for Type W weepvent, Euroweepvent, beak weep and small weepvent.



Type E cavitrays used with a lead flashing, where a new roof abuts an existing wall.

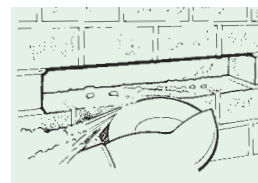

Step 1 - Three bricks are removed from the wall forming a 675mm opening (an angle grinder/cutter is ideal for cutting out).

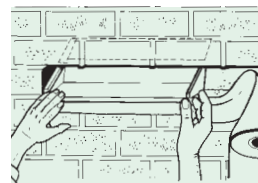

Step 2 - One cavitray is inserted together with the flashing intended for dressing over the skirting of the roof finish (flashing approx 50mm into wall). Lead flashing is not required in most remedial applications.

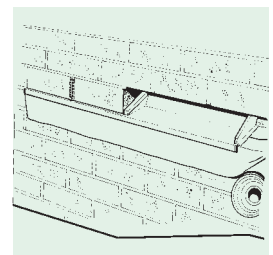

Step 3 - Two bricks are replaced in the wall into the cavitray. They are jointed and securely slate pinned, leaving the wall above safe and firm. A weepvent is incorporated in the middle perp. Two more bricks are removed again forming a three brick space. The flashing is extended and a second cavitray inserted. The integral U clip joins the trays, ensuring that no water can penetrate. Two more bricks are inserted and a weephole again formed. There are now two adjoining but completely self-contained cavitrays. The method is continued until the required run is completed. (Always bed on mortar. Do not dry bed)



phone 01935 474769 fax 01935 428223 email enquiries@cavitytrays.co.uk

Cavity Trays

Type E Cavitray

for remedial/refurbishment works

- Brick-sized cavitrays permit progressive insertion
- Anticapil interlocking to form long runs
- Cavity widths compatible - upstand adjusts to suit
- Unobstructed cavity compartment area with stand-alone discharge
- Easy compliance with building regulations
- Minimal disturbance to masonry - fitted from outside

(See previous page for Type E general details).

problem

How to introduce an effective DPC into an existing cavity wall in which the original damp-proofing element has been omitted, damaged, incorrectly formed or is suspect/faulty.

introduction

Existing cavity walls rely upon the use of damp courses to maintain dry status of the inner skin and dry status of the exterior skin whenever an intersection creates a change of level. In the past conventional damp courses have been used on high-rise developments and when building cavity walls "off the solid" or "off a ringbeam". Unfortunately, conventional damp courses do not permit the easy (and often satisfactory) creation of intricate construction details. Overlaps and joints fail, and unsupported laps spanning the cavity provide a weakness via which collected cavity water

may penetrate. Junctions with piers and columns are often precariously, incorrectly, and inconsistently fabricated on site. When dampness is eventually experienced, there is an urgent requirement to regularize construction economically and with the minimum of disturbance. The Type E cavitray is designed for such applications.

solution

Details of our Type E cavitrays are described on the previous pages. When used in remedial situations, the minimum of exterior masonry is disturbed (normally one course only). The Type E cavitray is a self-contained stand-alone unit with its own collection area and discharge outlet (via a weep/vent). It is therefore easy to identify and address specific areas and runs. This advantage is not available with other systems. The Type E cavitray for use in remedial applications may be supplied in various lengths, widths and depths. Thus the external skin masonry module encountered

on site may be matched. Long runs of trays are easily created, whilst maintaining self-contained and stand-alone status. Installation is from the outside of the building only.

sizes

Specify whether you require the standard cavitray size or a specific size to suit the length and depth of the masonry module of which your building is constructed.

material

Polypropylene solid DPC, injection moulded to ensure uniform thickness.

colour

Black.

survey service

We will be pleased to visit sites and advise on the most appropriate size of tray to suit your project.

bill of quantity wording

Type E cavitray from Cavity Trays of Yeovil, Somerset BA22 8HU (01935 474769).

State size of tray required

Cut out masonry in the external skin of the cavity wall in accordance with installation instructions provided by Cavity Trays of Yeovil. Insert one at a time into existing external skin. Replace bricks into cavitray within the wall. Incorporate weepvent in the middle of each cavitray. Ensure every tray and all bricks are correctly bedded in mortar and slate pin to make safe and firm. Adjoining trays clip together. Remove adjoining brick. Continue operation until required run is completed. Clearly specify all angles and sizes. Total run in metres equals Request liability/conformity document upon completion.

ordering/regulations

See inside back cover for details.

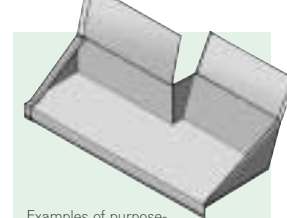

Examples of purpose-made trays which accommodate cavity columns.



Type E cavitrays used without flashing, over an existing opening where the original damp course has failed or has been omitted. The exact course in which the cavitray is introduced varies depending on the construction detail.

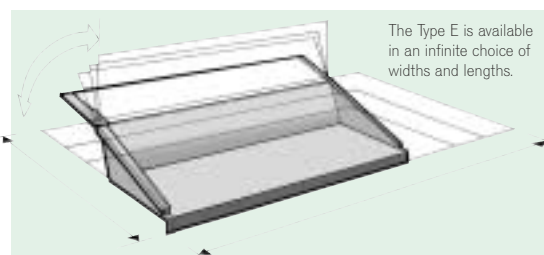

The Type E is available in an infinite choice of widths and lengths.



Type F Corrugated Flashing

for use with PVC corrugated sheeting

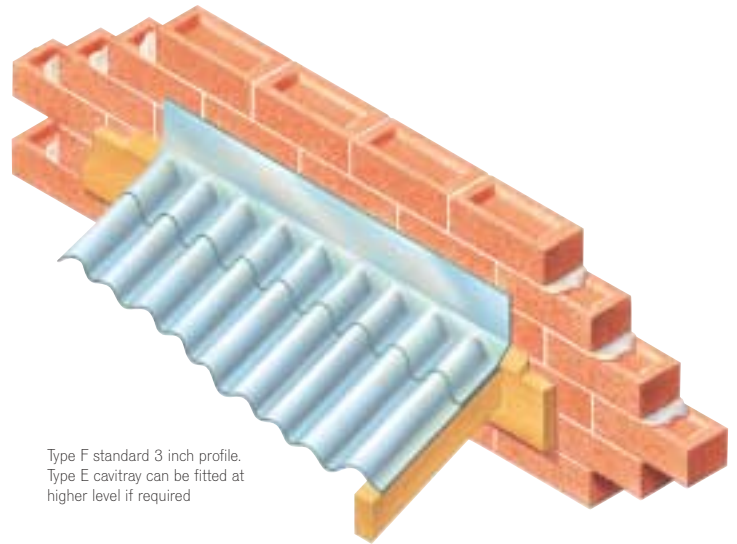

Type F standard 3 inch profile.
Type E cavitrays can be fitted at higher level if required

- Fills and flashes sheet top with masonry
- Adjusts to suit different roof angles
- Blends with roof finish

technical observations

Corrugated flashings suit angles of roof from 17.5 degrees up to 60 degrees. Lightweight appearance matches roof sheets. Easily and simply fixed using standard roofsheet fixings. Branded with name and logo as proof of type and accompanying warranty.

problem

How to create corrugated flashing suitable for use with plastic roof sheets only.

introduction

It is a difficult task to adequately join or flash the gap between the top of a translucent corrugated roof and a wall. Examples can be seen everywhere of cracking cement fillets, accumulations of mastic, and applications of tape which will not stretch into the sheet profile and up the wall without creasing and causing difficulties.

solution

The new Type F corrugated flashing units can be used on porches, lean-tos, outhouses, conservatories, or temporary structures having lightweight translucent corrugated roof sheeting. The Type F flashing unit incorporates a unique integral hinge, usually making it suitable for any angle of roof from 17.5° up to and including 60°. The units are fixed simply by positioning before securing the top of sheet fixings, which then hold the units in place. The Type F fits the corrugations snugly, whilst the upstand springs to shape vertically against the wall.

The upstand can then be finished off with either:

- 1 Type E cavitrays (if a room and Building Regulations stipulate).
- 2 Standard cover flashing tape or conventional lead or aluminium cover flashing.

size of wall flashings

Type F flashing units are available in the following profiles:
Standard 3"/75mm asbestos.
Standard 3"/75mm iron.
Miniature.
Grecca box profile 76/18.
Box profile 16mm.
Box profile 14mm.
Onduline standard profile.

Approximate dimensions 150mm x 85mm upstand x 715mm lengths. (Units purposely designed to a length slightly shorter than width of standard sheet to prevent all overlaps coinciding and contributing to heat discolouration.)

Non-standard sizes available to order.

type F corrugated ridge

The Type F corrugated ridge is designed to act as a one-part ridge on structures

incorporating translucent roof sheets.

The ridge provides a simple, neat and inexpensive way of uniting and finishing corrugated sheets which meet in an apex format. Type F corrugated ridge flashings are suitable for roof pitches of 17.5 degrees up to 60 degrees.

size of ridge flashing

700mm x 160mm each side. (Units purposely designed to a length slightly shorter than the width of a standard sheet, to prevent all overlaps coinciding and contributing to heat discolouration.) Standard 3"/75mm asbestos profile.

material

PVCU classified "self-extinguishing". Onduline profile available in black polypropylene, toning grade only.

colour

Natural translucent. Onduline profile available in black only.

installation/site work

In storing, handling and fixing of units, one should exercise care and attention as specified and exercised with standard translucent roofing sheets. Follow sheet installation

instructions. Corrugated units are fixed simply by positioning before securing the top of sheet fixings, which then hold the units in place. Observe standard sheet overlap dimensions.

bill of quantity wording

Type F corrugated flashing unit or corrugated ridge from Cavity Trays of Yeovil, Somerset BA22 8HU (01935 474769). Unit to be fixed in accordance with manufacturer's instructions.

Corrugated flashings to be secured at top of sheets prior to securing the top of sheet fixings. Total measured run including laps = Request liability/conformity document upon completion.

ordering/regulations

See inside back cover for details.

related products and applications

Consider use of Type E Cavitrays within the wall above the Type F flashing unit if the structure is to be damp-proofed within the definition of the Building Regulations.

